

CAMBRIDGE

British
English

Super Safari

Pupil's Book



www.miladcollege.com

Herbert Puchta Günter Gerngross Peter Lewis-Jones



Map of the book

Hello! (pages 4–7)	
Vocabulary Mike, Gina, Polly, Leo	Chant: Grammar What's your name? I'm ...
Total physical response: Say 'hello', Smile, Shake hands, High five	Song: Hello!

1 My school (pages 8–15)				
Vocabulary board, paper, computer, desk, crayon, pencil case	Chant: Grammar This is my (crayon).	Story and value <i>The medals</i> Appreciating differences	CLIL Move your body	Thinking skills Sorting
Total physical response: Open your book, Pick up your crayon, Draw a picture, Oh no! It's broken			Song: I've got a pencil case on my desk.	

2 My body (pages 16–23)				
Vocabulary arms, hands, feet, legs, body, head	Chant: Grammar I can (clap my hands).	Story and value <i>Ouch!</i> Looking after someone	CLIL Animal bodies	Thinking skills Noticing details
Total physical response: Kick a ball, It's a goal, Clap your hands, Hug your friend			Song: Shake your body!	

3 My room (pages 24–31)				
Vocabulary toy box, bookcase, lamp, mat, window, door	Chant: Grammar Where's my (book)? It's in / on / under the (bookcase).	Story and value <i>Goodnight, Dad</i> Being patient	CLIL Being tidy	Thinking skills Comparing
Total physical response: Where's my rabbit?, Look under the mat, Look in the toy box, Ah, here it is			Song: My messy room	

4 In the jungle (pages 32–39)				
Vocabulary rhino, tiger, elephant, snake, spider, crocodile	Chant: Grammar Is it a (rabbit)? Yes, it is. / No, it isn't.	Story and value <i>The jungle</i> Being creative	CLIL Where animals live	Thinking skills Noticing details
Total physical response: Walk through the jungle, Turn around, It's a big snake, Run away			Song: Walking through the jungle	

5 Fruit and vegetables (pages 40–47)

Vocabulary potatoes, pineapple, carrots, tomatoes, watermelon, banana	Chant: Grammar Do you like (vegetables)? Yes, I do. / No, I don't.	Story and value <i>The fruit salad</i> Healthy eating	CLIL Food types	Thinking skills Comparing, contrasting
Total physical response: Hmm ... I'm hungry, Look, there's an apple, I can't reach. Jump ... Ouch			Song: Do you like vegetables?	

6 My town (pages 48–55)

Vocabulary bus stop, park, school, toy shop, supermarket, zoo	Chant: Grammar Let's go to (the park).	Story and value <i>The present</i> Keeping your town clean	CLIL The environment	Thinking skills Creating associations
Total physical response: It's a toyshop ... wow, What's this?. Look ... a robot, Oh no			Song: Come and see my town!	

7 Jobs (pages 56–63)

Vocabulary farmer, police officer, builder, doctor, firefighter, teacher	Chant: Grammar My (mum)'s a (doctor).	Story and value <i>Firefighters</i> Helping others	CLIL Jobs and vehicles	Thinking skills Sorting
Total physical response: I'm a farmer, Listen ... what's that?, It's a bull, Run			Song: Let's play firefighters!	

8 The weather (pages 64–71)

Vocabulary rainy, windy, cold, snowy, hot, sunny	Chant: Grammar Is it (hot / cold / sunny / snowy)? Yes, it is. / No, it isn't.	Story and value <i>The island</i> Be prepared	CLIL Weather and geography	Thinking skills Sequencing
Total physical response: It's a hot and sunny day ... phew, Put your hat on, Eat an ice cream ... yum, Oh no, the sea! Run			Song: What's the weather like today?	

9 In the countryside (pages 72–79)

Vocabulary tree, leaves, frog, grass, flower, bee	Chant: Grammar The bee is / isn't (big). It's (small).	Story and value <i>The bee</i> Respecting nature	CLIL Animal habitats	Thinking skills Sorting
Total physical response: I'm walking in the garden, Look, it's a flower, Look, it's a bird, Ouch! It's a tree			Song: Four frogs in a tree	

Phonics (pages 80–89)

Unit 1: 'a' cat, dad	Unit 2: 'i' sit, pin	Unit 3: 'e' bed, pen	Unit 4: 'o' dot, pot	Unit 5: 'u' cut, bus	Unit 6: 'm' mum, mat	Unit 7: 'j' jam, job	Unit 8: 'l' log, lamp	Unit 9: 'w' wet, wow	Phonics review
--------------------------------	--------------------------------	--------------------------------	--------------------------------	--------------------------------	--------------------------------	--------------------------------	---------------------------------	--------------------------------	--------------------------

Hello!

1 CD1
02 Listen and point. Say the names.





Listen and chant.



Listen and act. Listen and colour.





Listen and sing.



www.miladcollege.com

1

My school

1 CD1
09

Listen and point. Say the words.

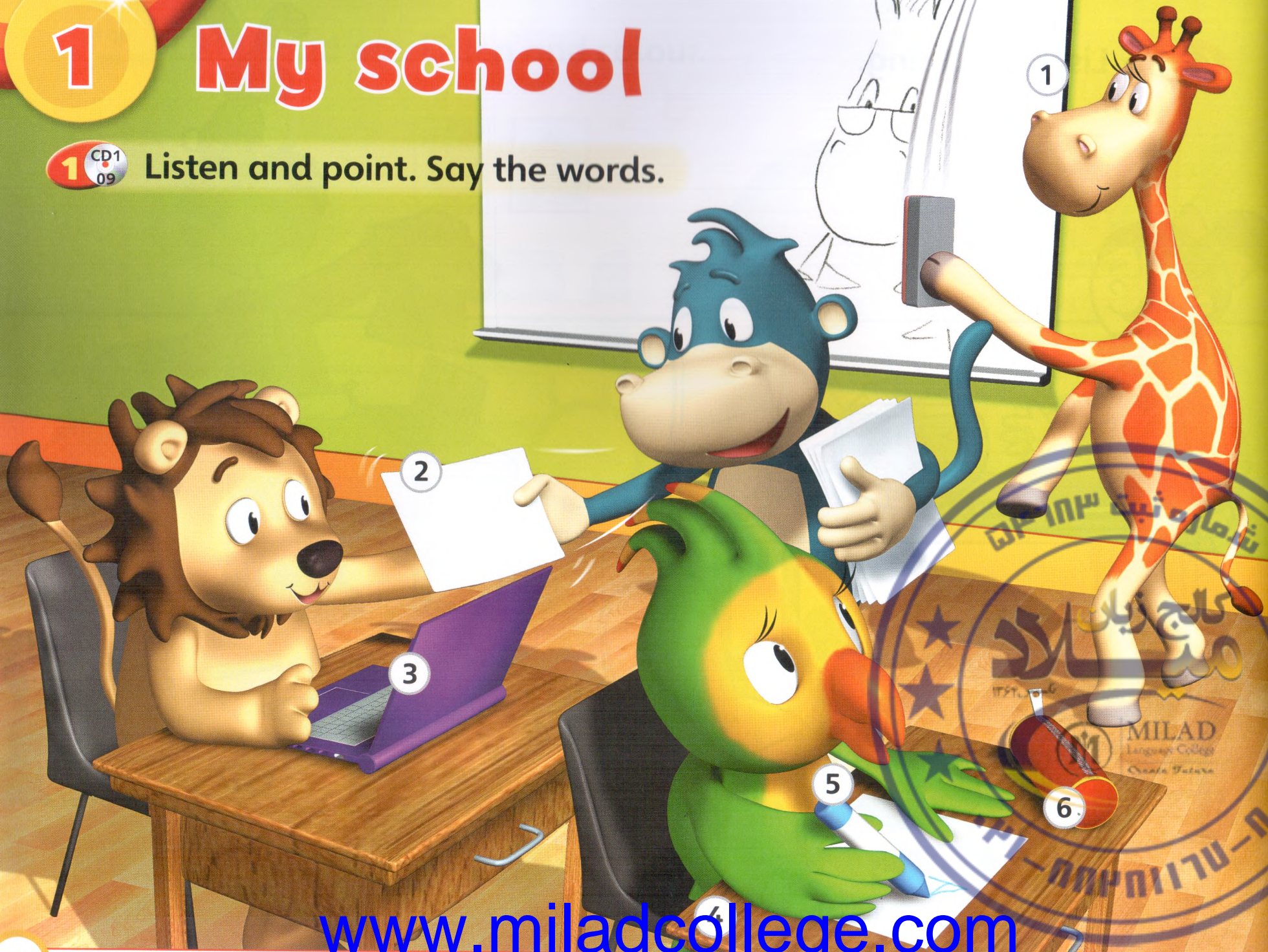

2 CD1 10

Listen and trace. Chant.

1

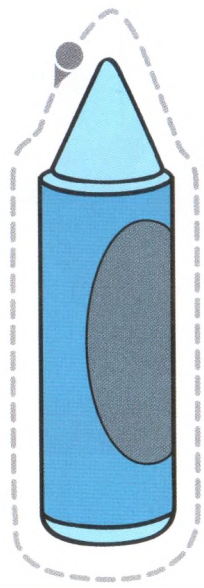

2

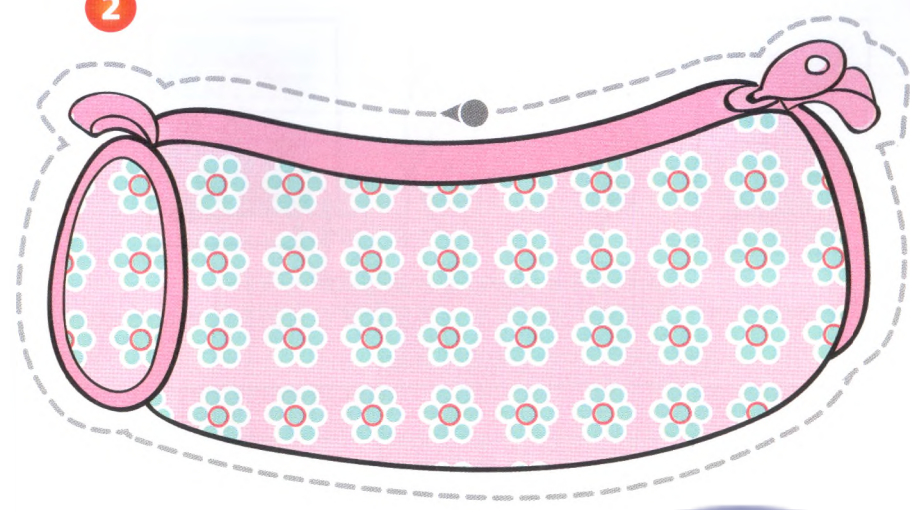

3

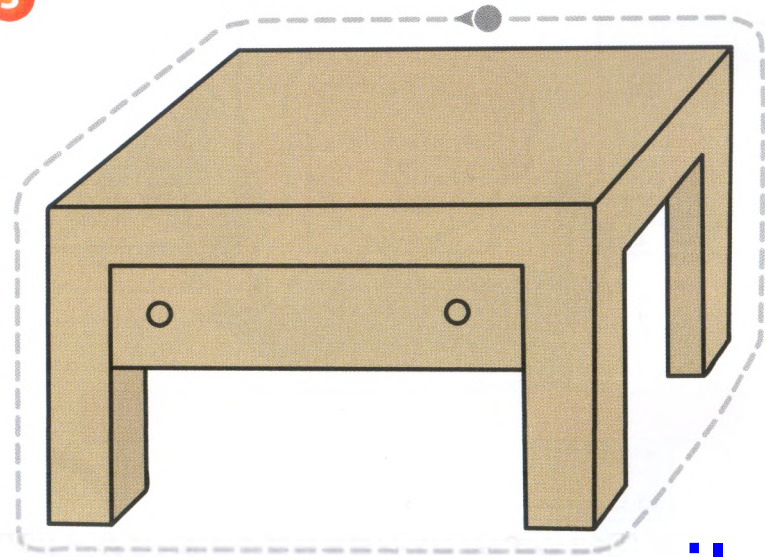

4

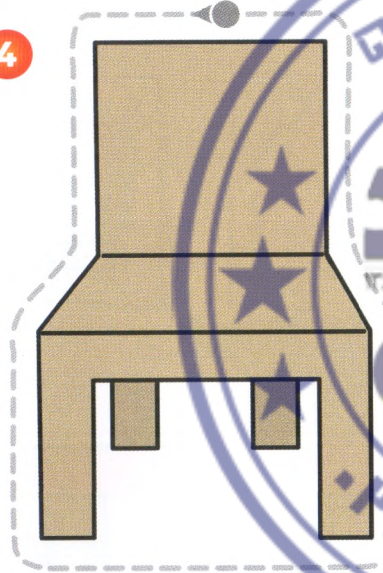

Listen and act. Listen and colour.

1



2



3



4

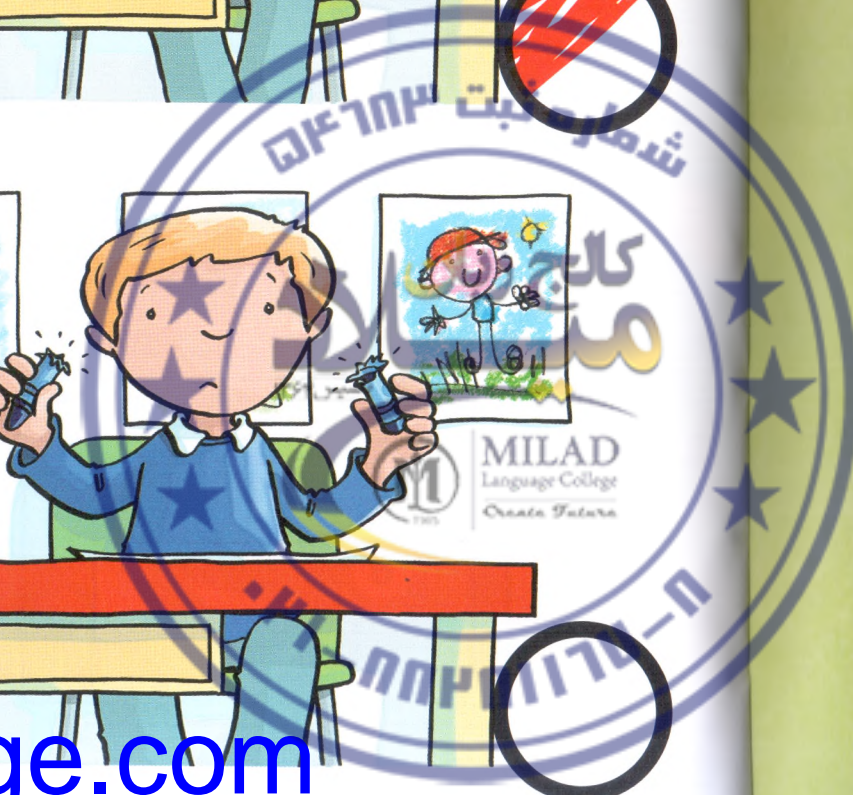

Listen and sing.



The medals





Move your body

6 CD1
20

Listen and point. Trace and say the words.

1



3



2



4



7 Think! Look and match. Say the actions.

1



2



3



www.miladcollege.com

2

My body

1 CD1
23

Listen and point. Say the words.



www.miladcollege.com



Listen and trace. Chant.



Listen and act. Listen and colour.





Listen and sing.



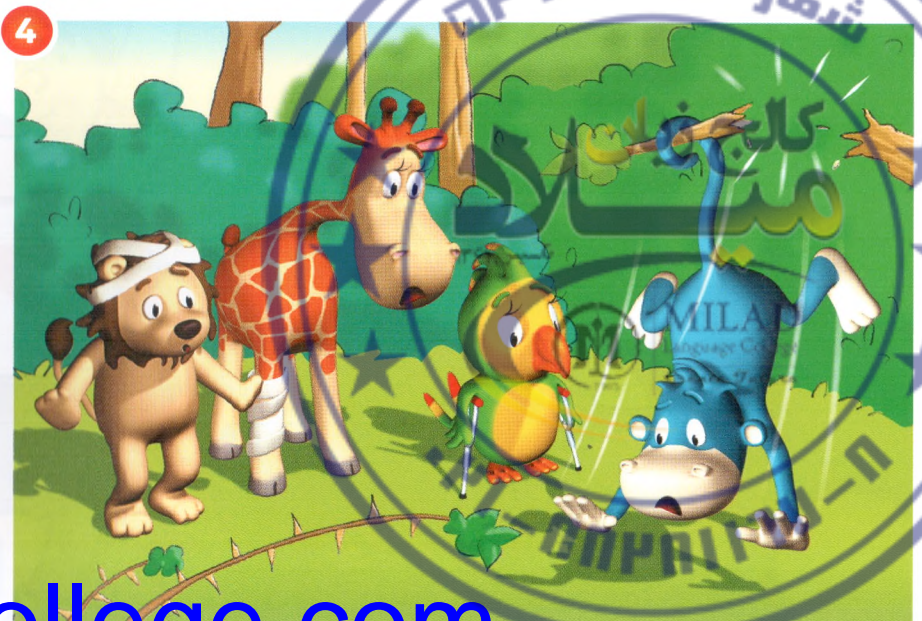



Animal bodies

6  Listen and point. Trace and say the words.

1



2



3



4



7 Think! Look and match. Say the words.

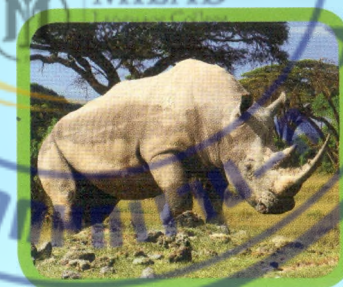
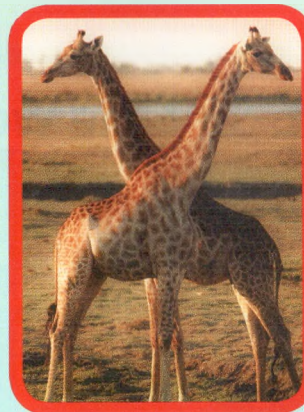

www.miladcollege.com

3

My room

1 CD1
37

Listen and point. Say the words.



www.miladcollege.com

2 CD1
38

Listen and circle. Chant.

1

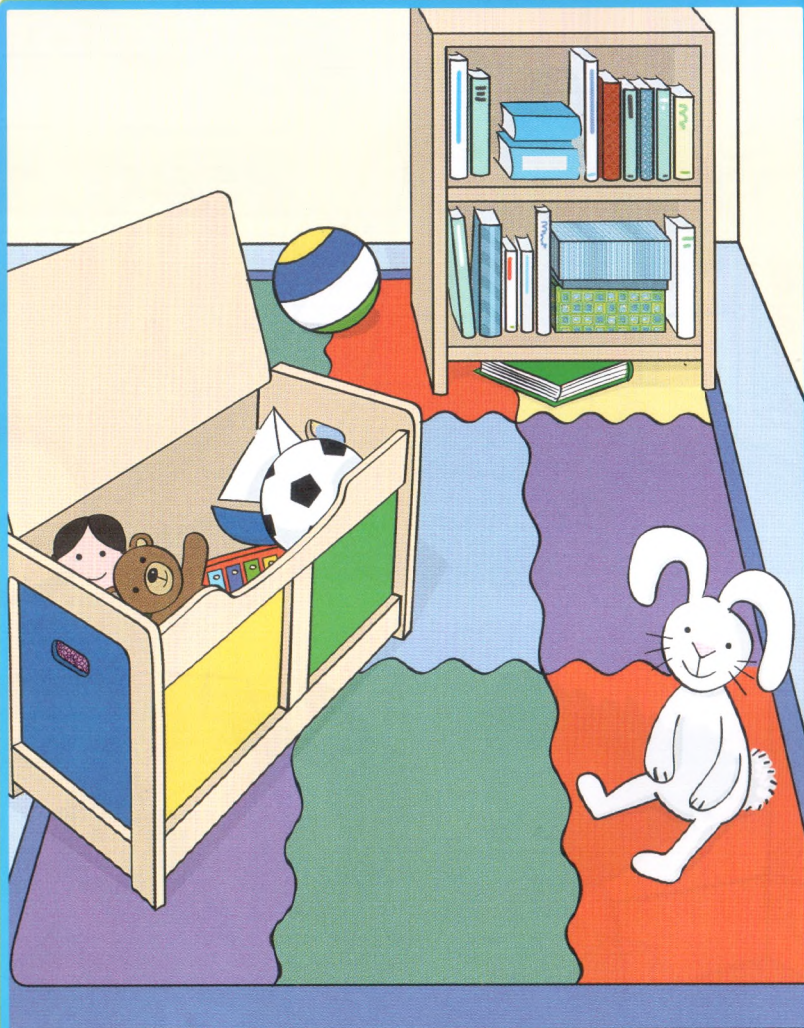

2



Listen and act. Listen and colour.





Listen and sing.



Goodnight, Dad

1



2



3



4





Being tidy

6  Listen and point. Draw and say the words.

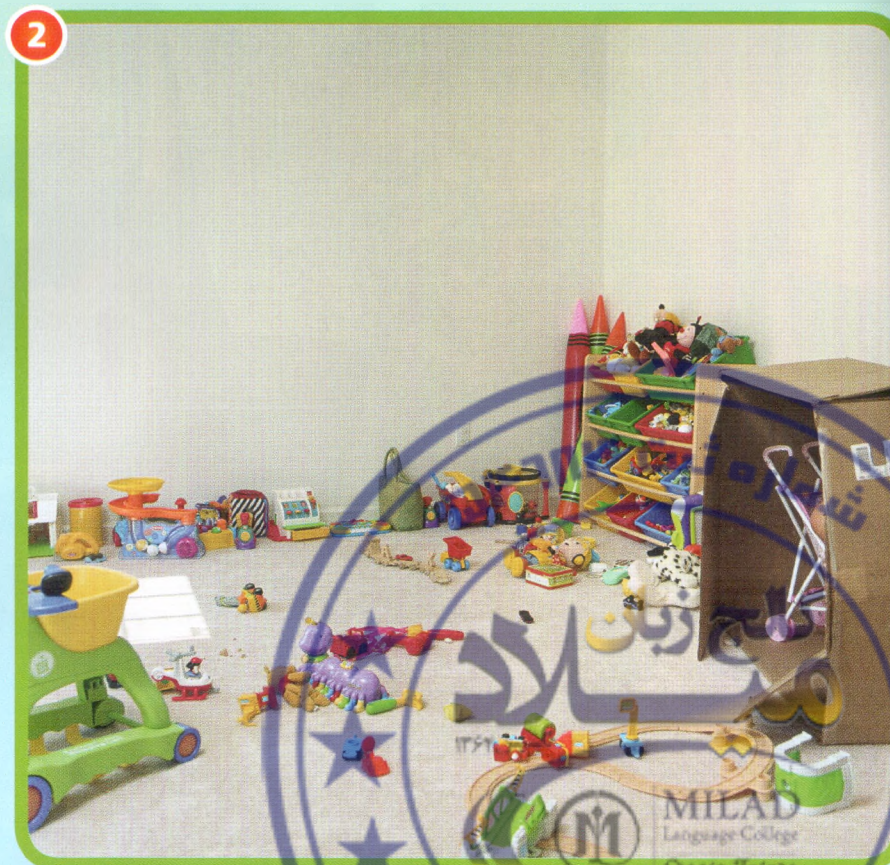
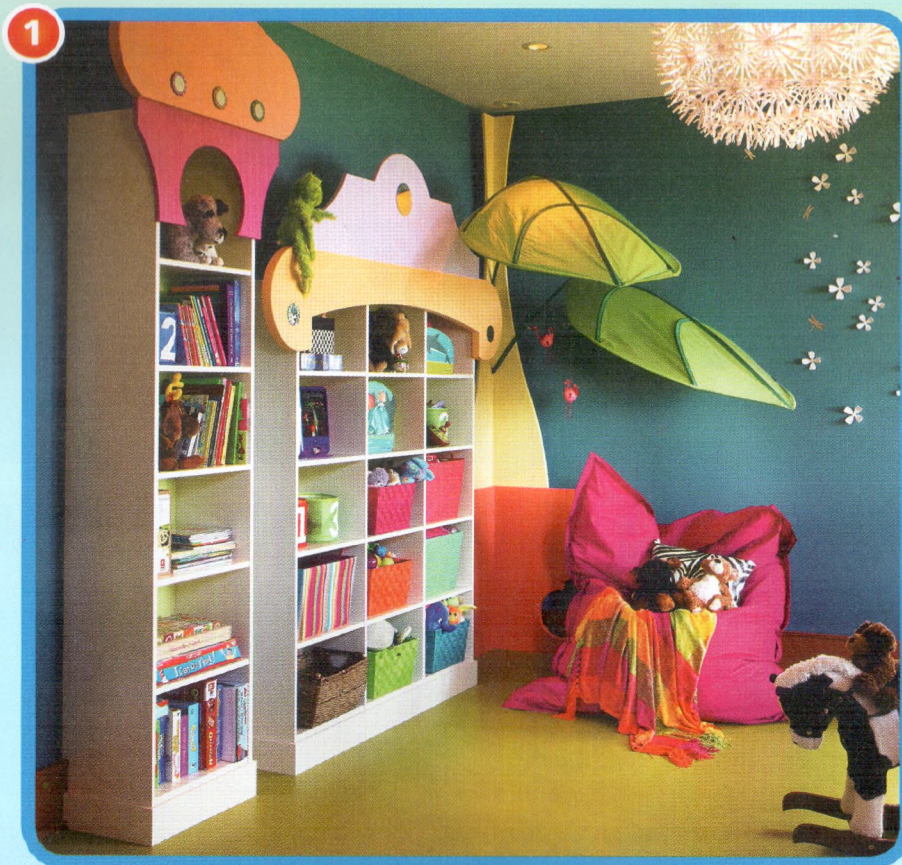

www.miladcollege.com

7 Think! Spot the difference. Circle the objects and say.

1



2



Listen and trace. Chant.



Listen and act. Listen and colour.



Listen and sing.

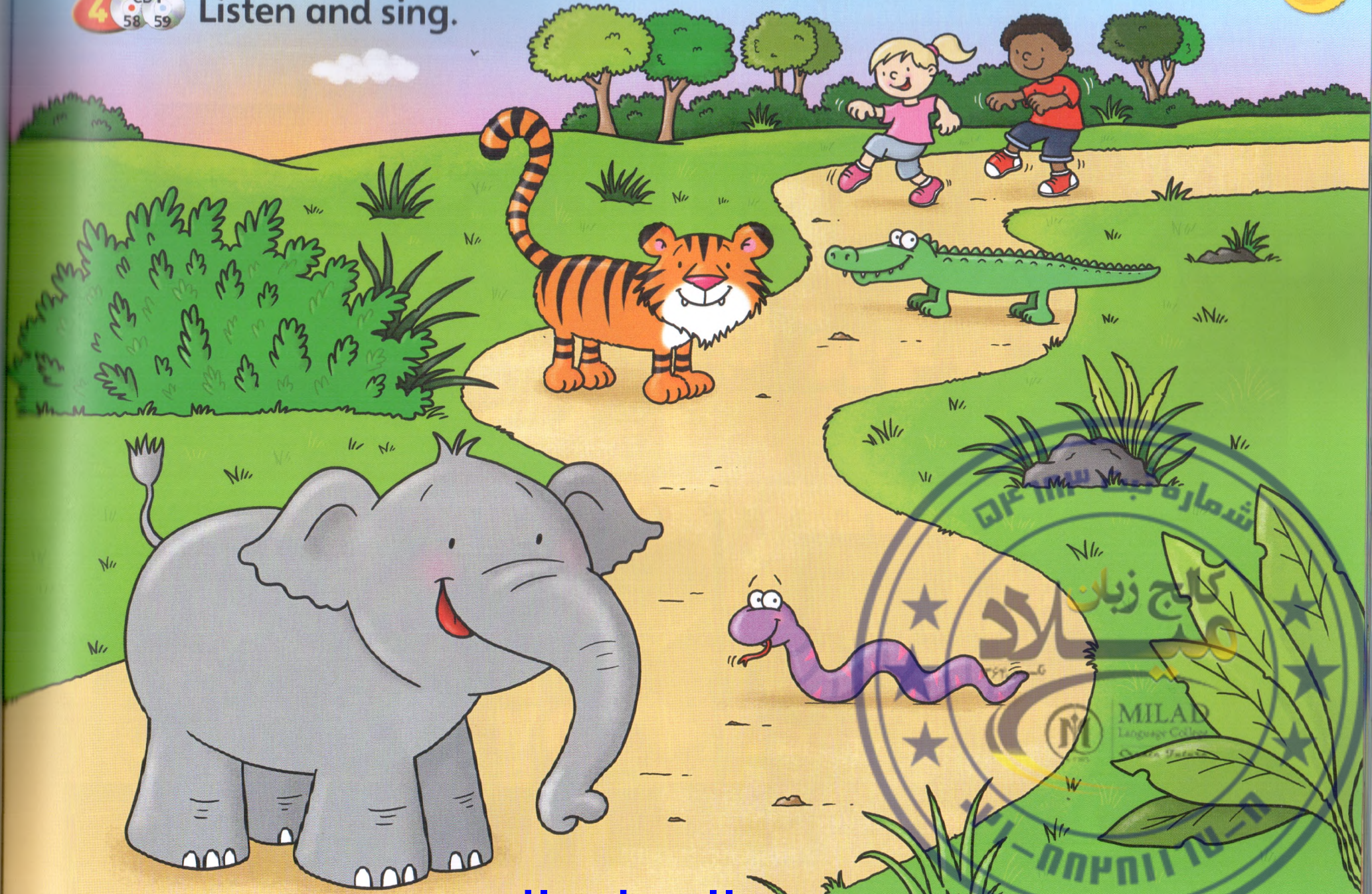





Where animals live

CD1
63

Listen and point. Trace and say the animals.

1

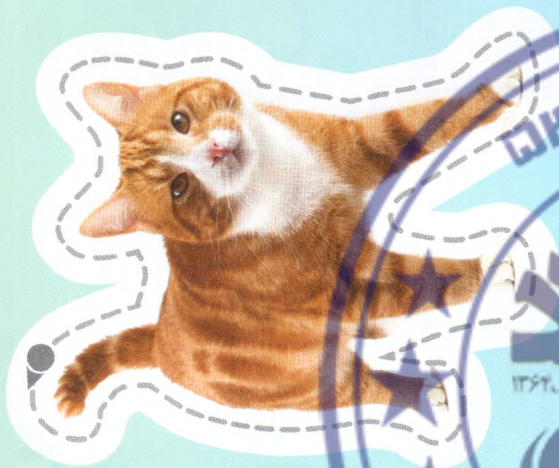

2



4

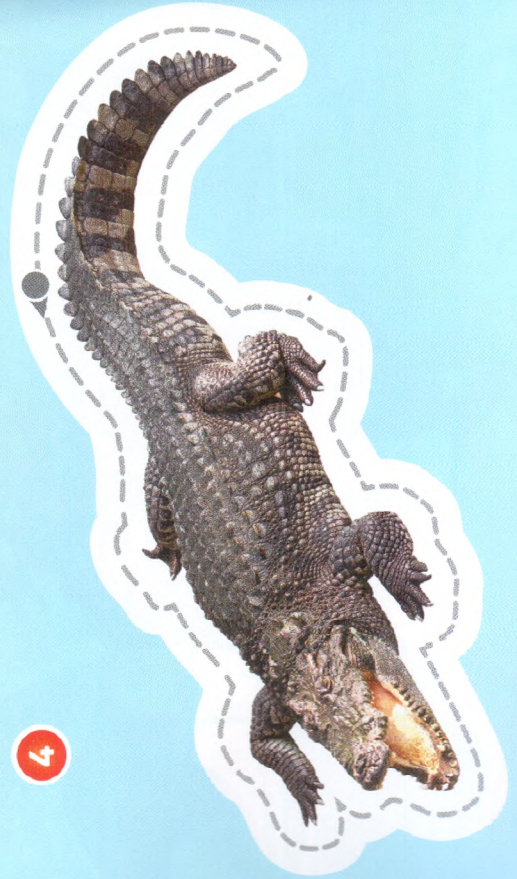

3



7 Think! Look and circle. What's wrong?



www.miladcollege.com

5

Fruit and vegetables

1 CD1
65

Listen and point. Say the fruit and vegetables.



www.miladcollege.com

2 CD1
67 Listen, trace and colour. Chant.

1

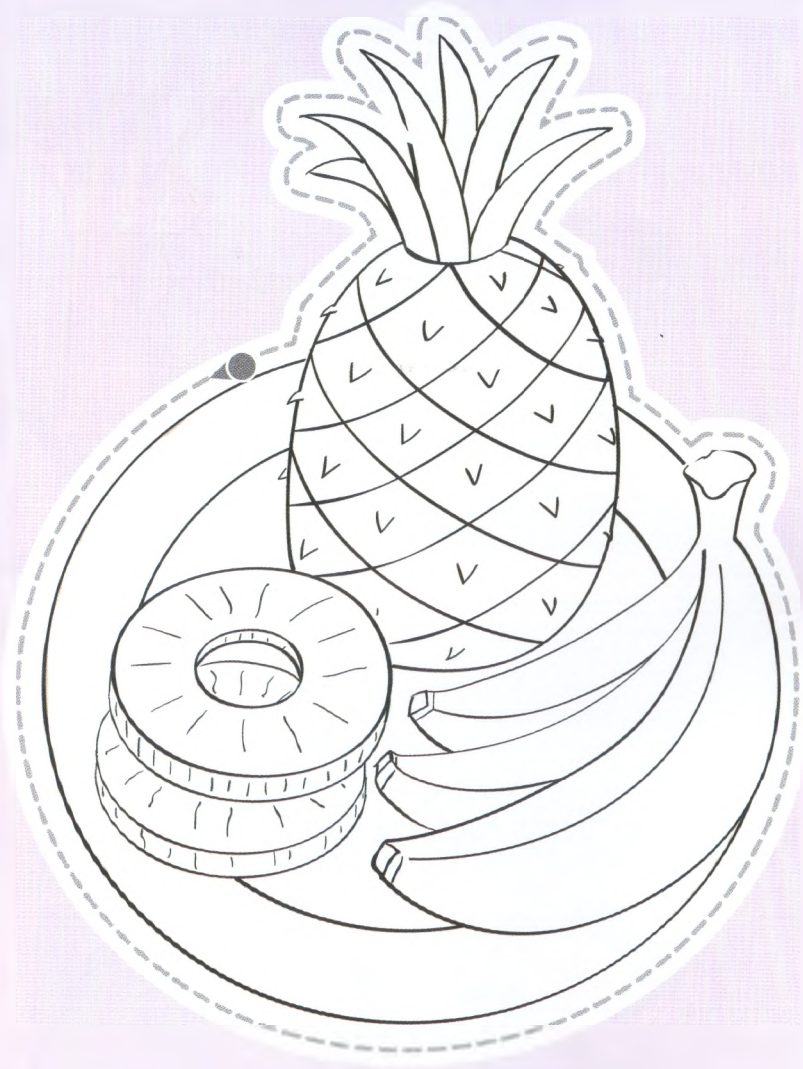

2



Listen and act. Listen and colour.



Listen and sing.



The fruit salad

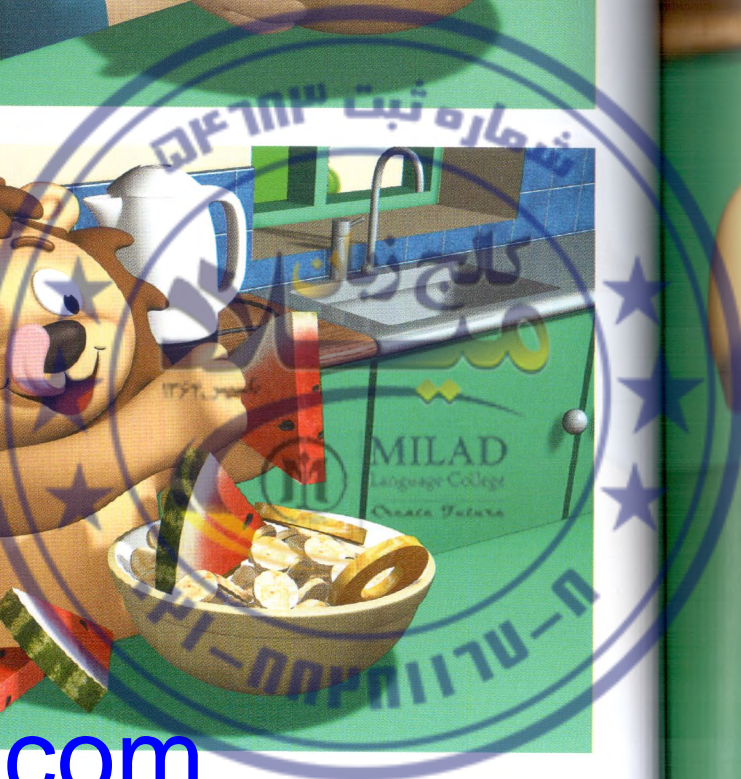
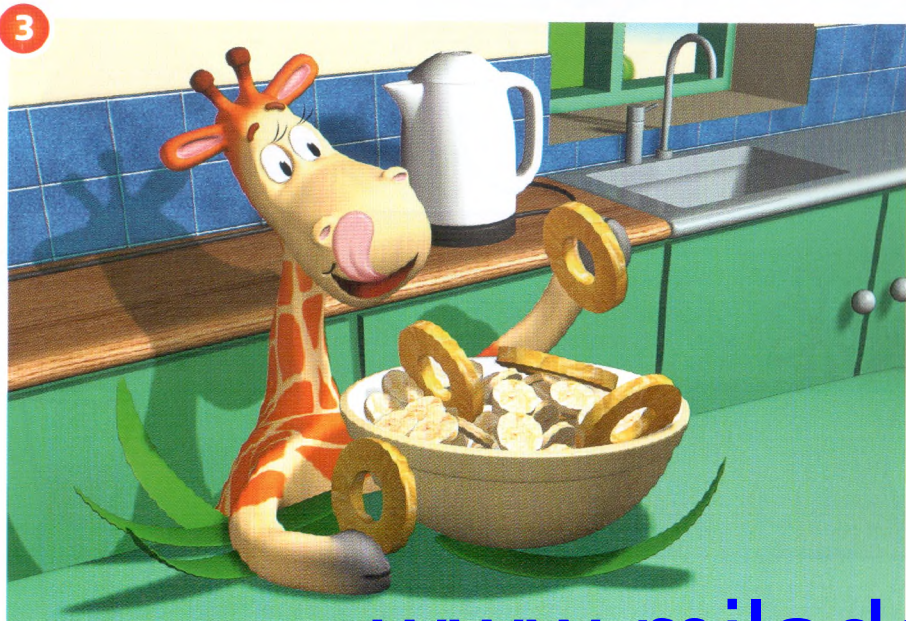



Food types

CD2
6 10

Listen and point. Trace and say the fruit and vegetables.

1

2

3

4



MILAD
Language College
Create Future

7

Think!

Look and circle the fruit.

1



2

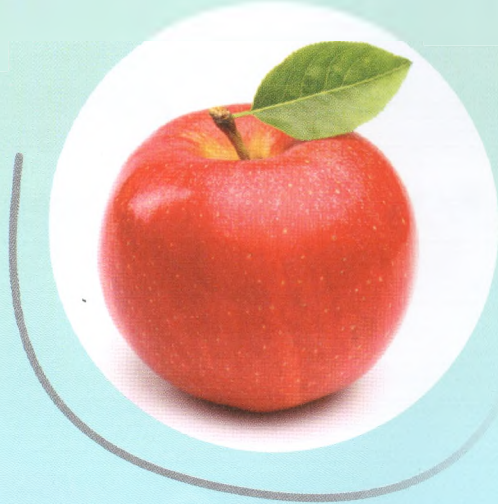

3



4



5



6



6

My town

1

CD2
13

Listen and point. Say the places.

2



3

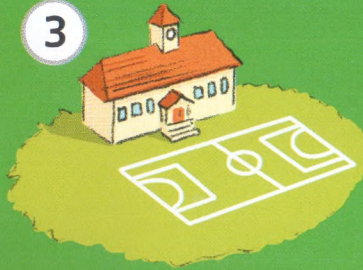

4



6



5

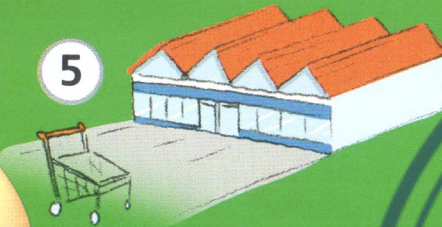

1

Listen and trace. Chant.



Listen and act. Listen and colour.

1



2



3

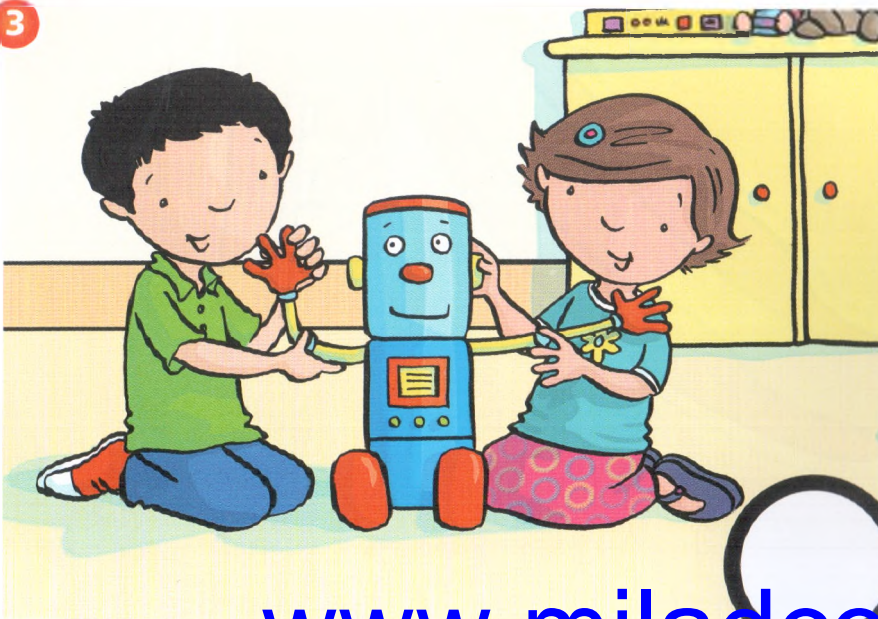

4

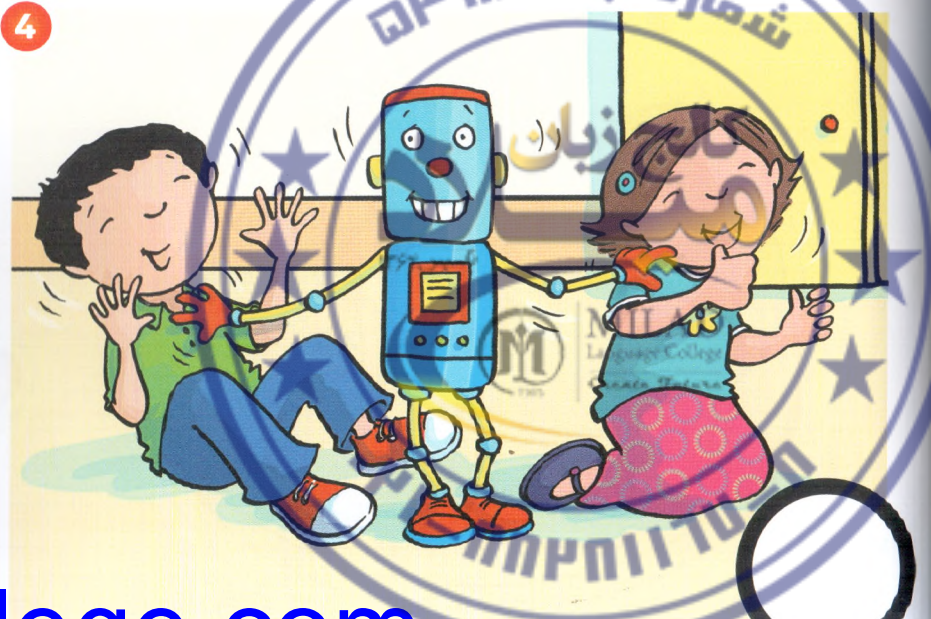

Listen and sing.

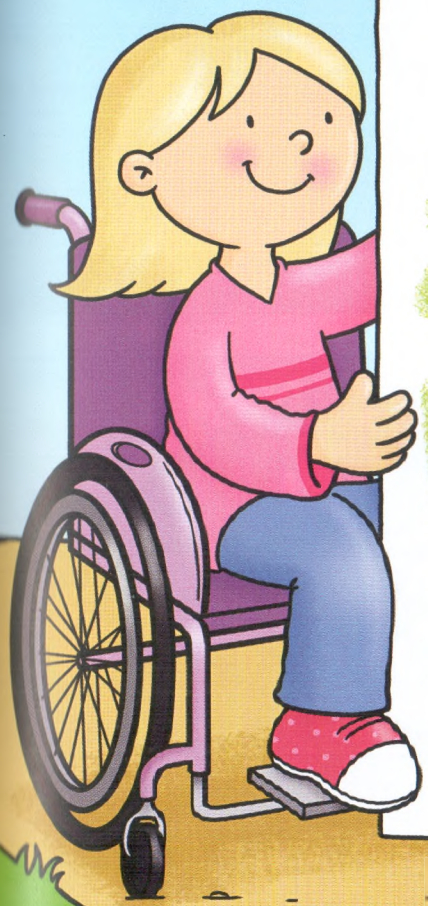

The present





The environment

6 ^{CD2} ₂₃ Listen and point. Draw and say.



7 Think! What's wrong? Look and circle.



www.miladcollege.com

7

Jobs

1 CD2
25

Listen and point. Say the jobs.



www.miladcollege.com

2 CD2 26

Listen and match. Chant.

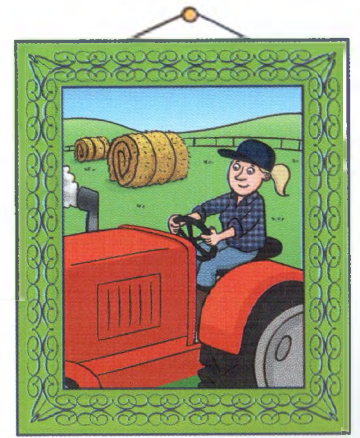

Listen and act. Listen and colour.

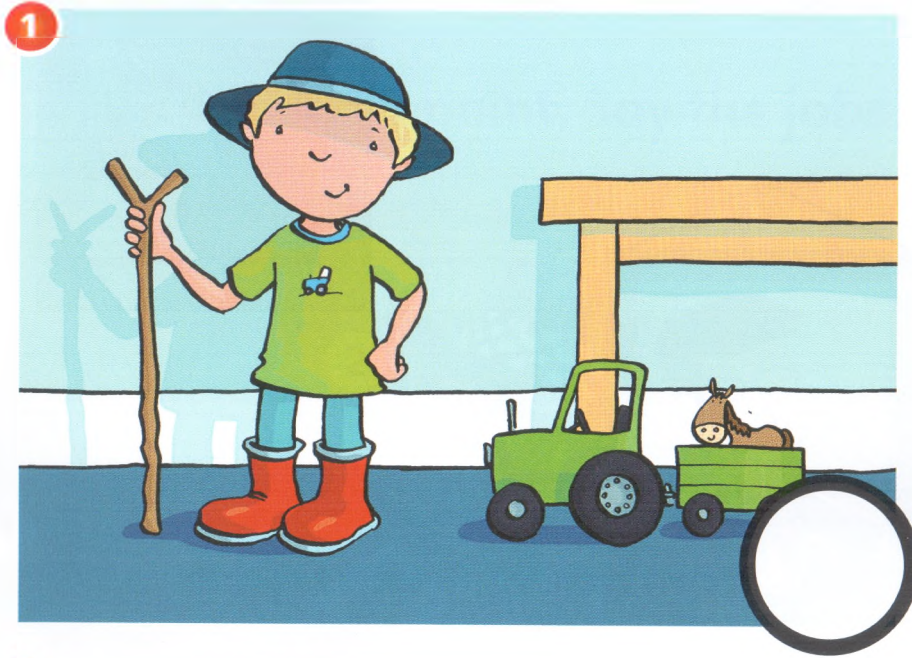

Listen and sing.



Firefighters





Jobs and vehicles

6 CD2 36 Listen and point. Trace and say the words.

1



2



3



4



7 Think! Look and match. Say the words.

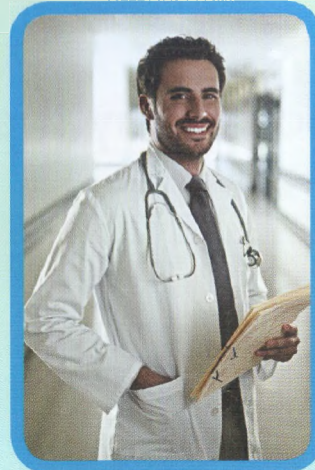

8

The weather

1

CD2
39

Listen and point. Say the words.

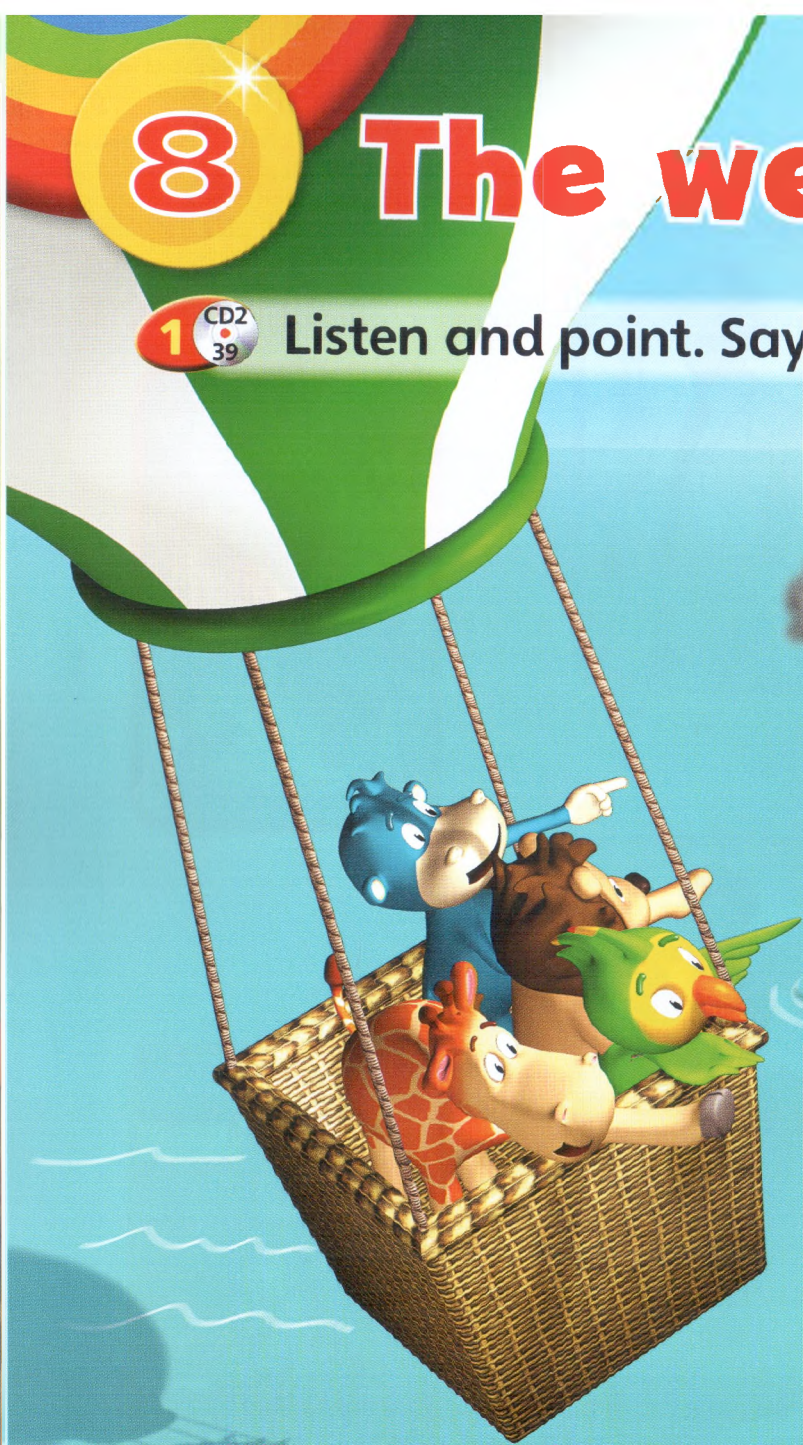

2 CD2
40

Listen and match. Chant.

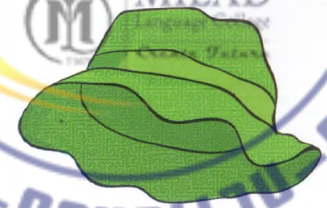
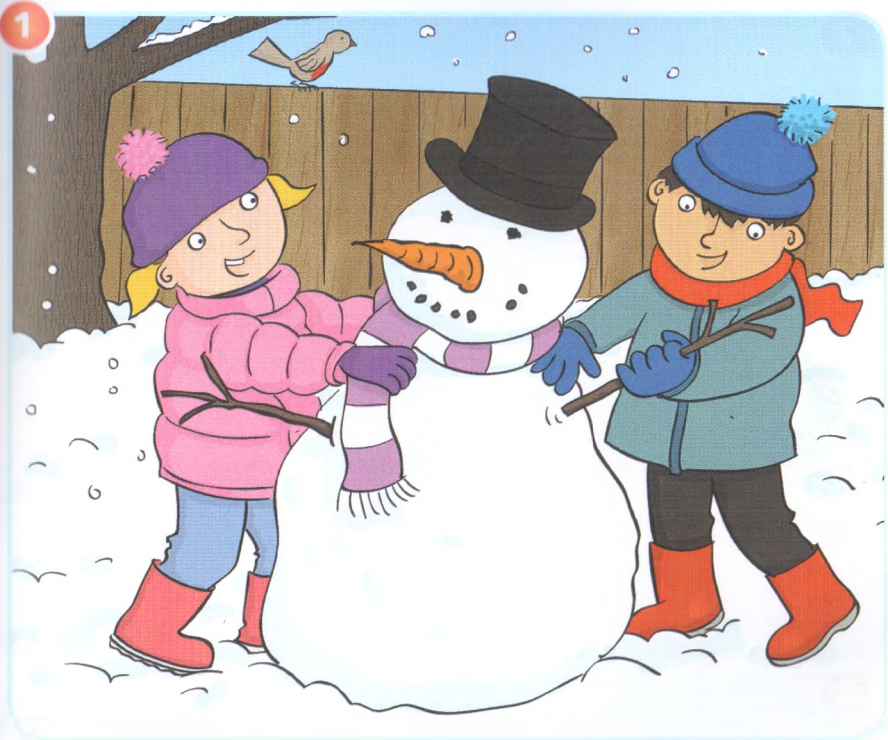

Listen and act. Listen and colour.



Listen and sing.



The island

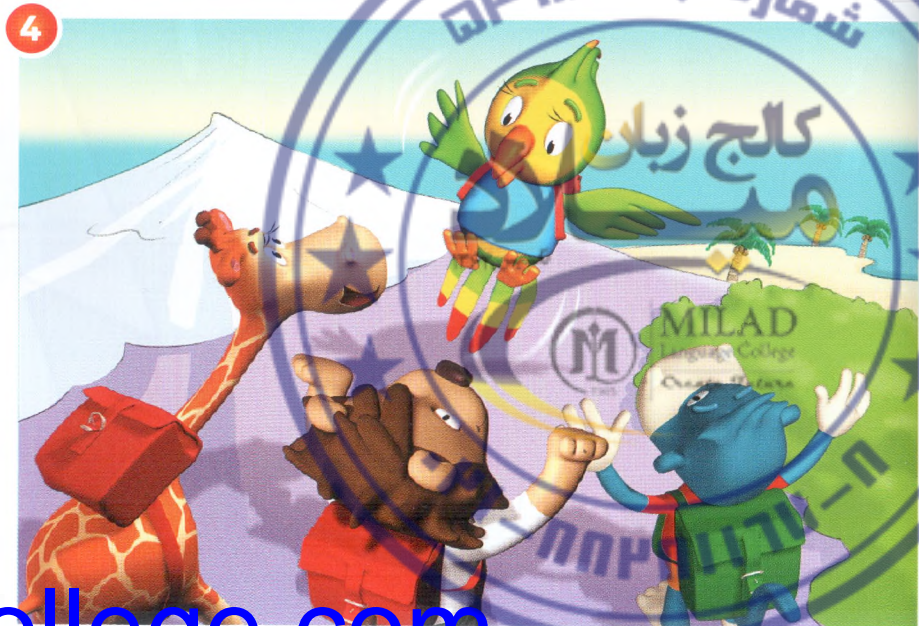
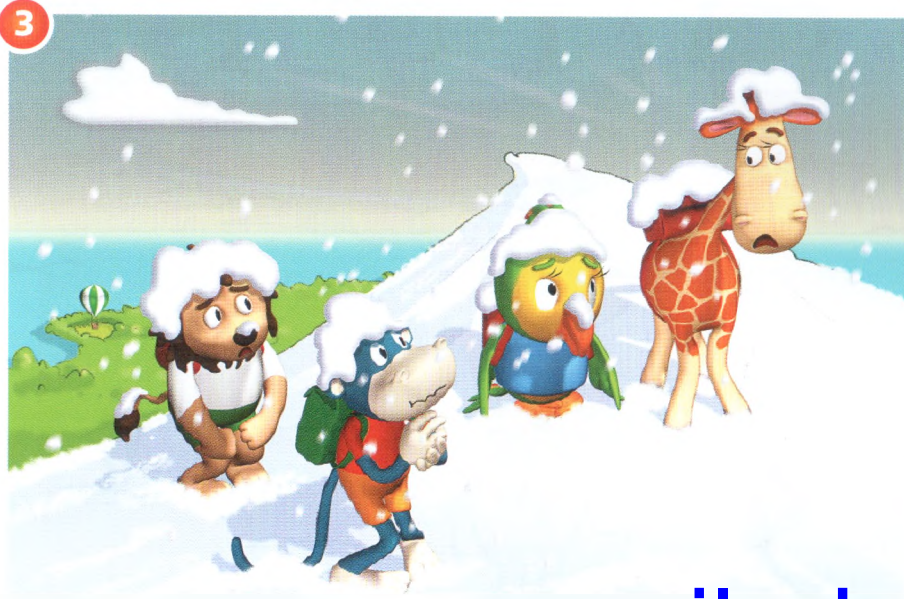



Weather and geography

6  Listen and point. Circle and say the words.



7 Think! What's next? Match and say the words.

1



2



3



9

In the countryside

1

CD2
51

Listen and point. Say the words.



Listen and circle. Chant.

1



2

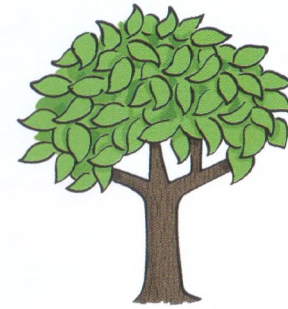

Listen and act. Listen and colour.



Listen and sing.

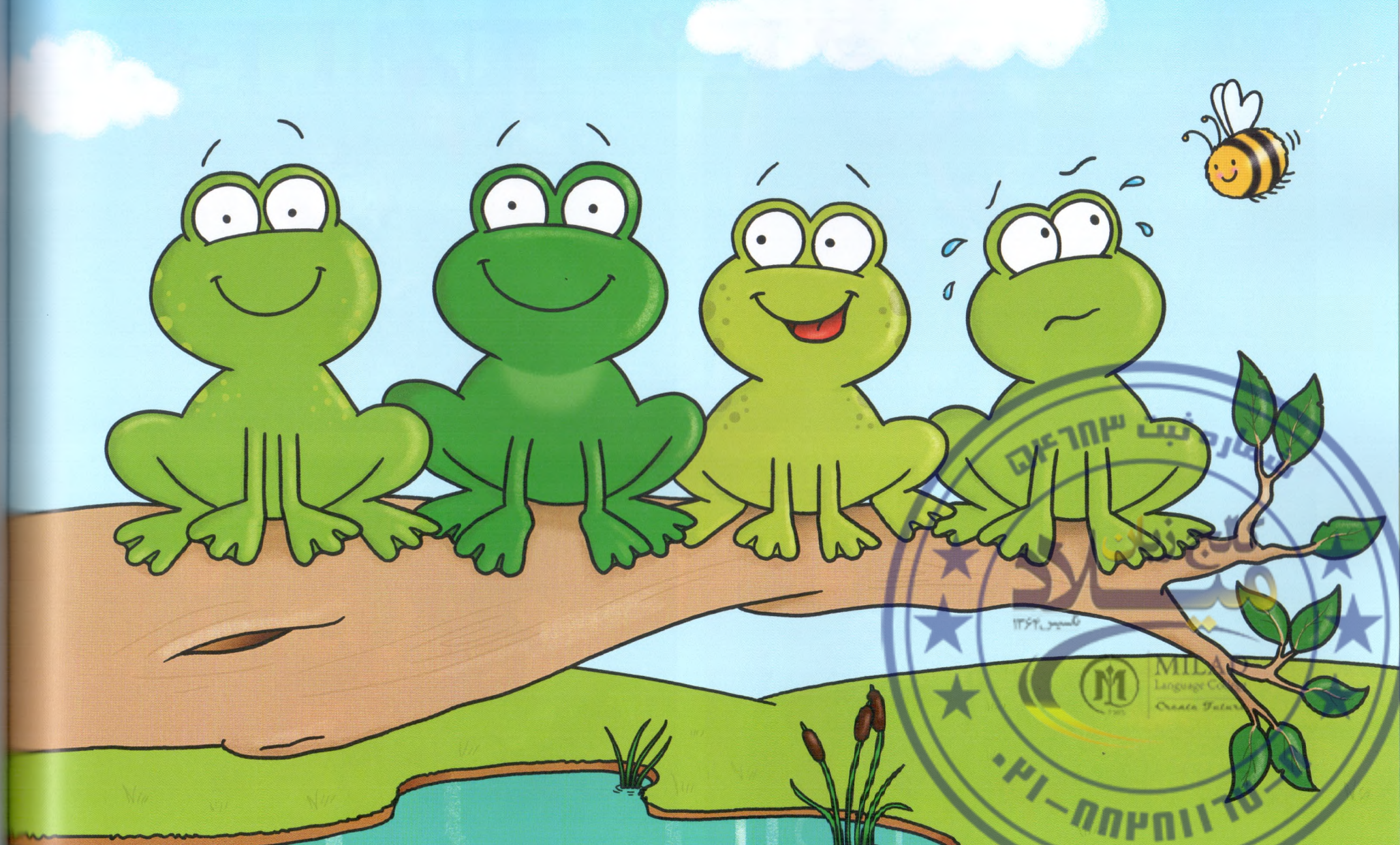

The bee

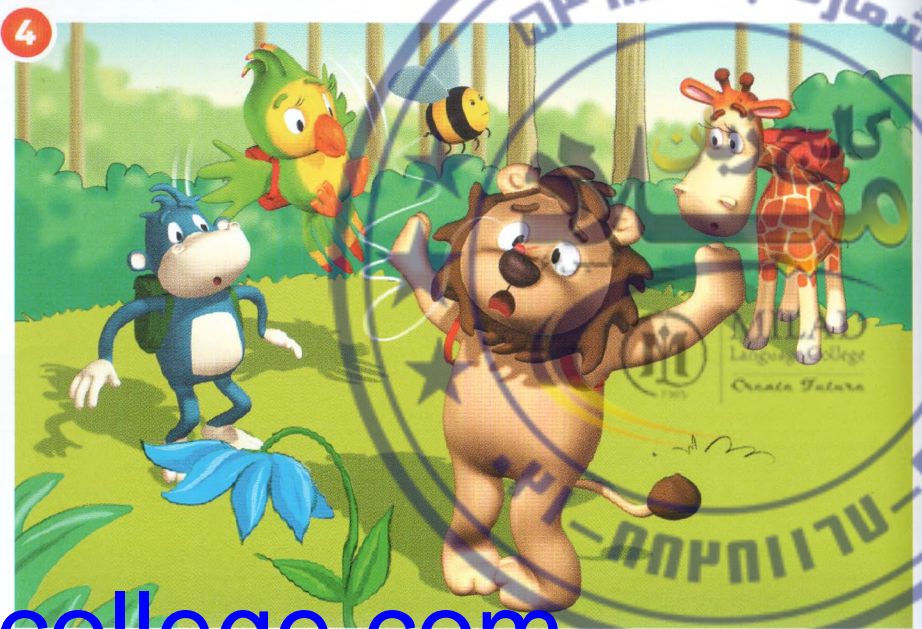



Animal habitats

6  Listen and point. Trace and say the words.

1



2



3



4



7 **Think!** Look and match. Say the words.

1



2



3



4



www.miladcollege.com

1 Look and find.

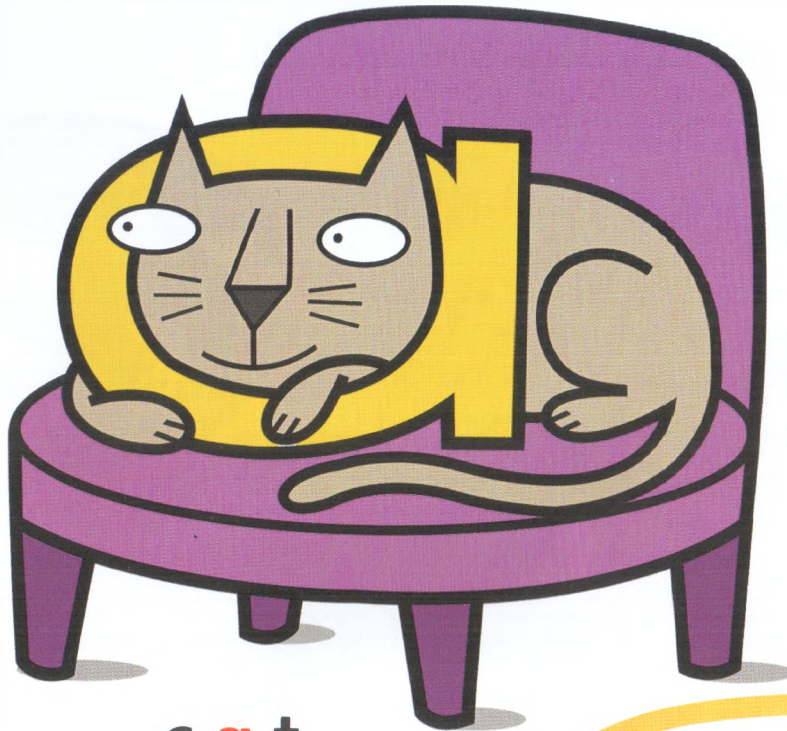
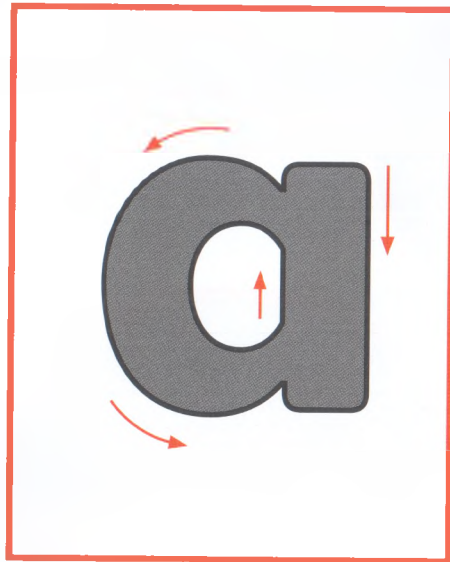

cat



dad

2 CD1 Listen and join in.
21

www.miladcollege.com



1 Look and find.

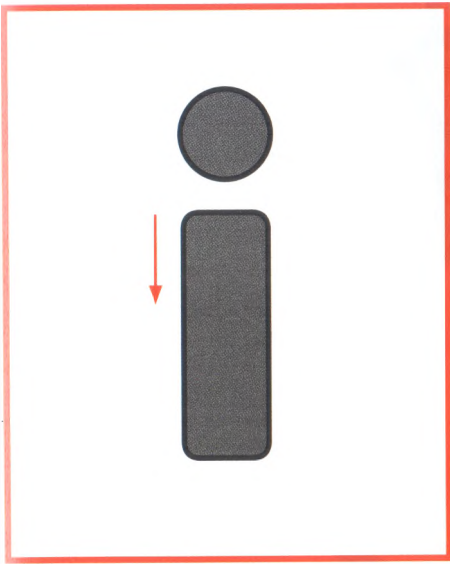

sit

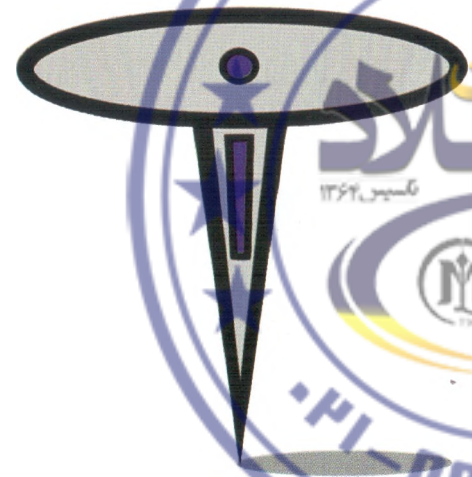

pin



2 Listen and join in.

1 Look and find.

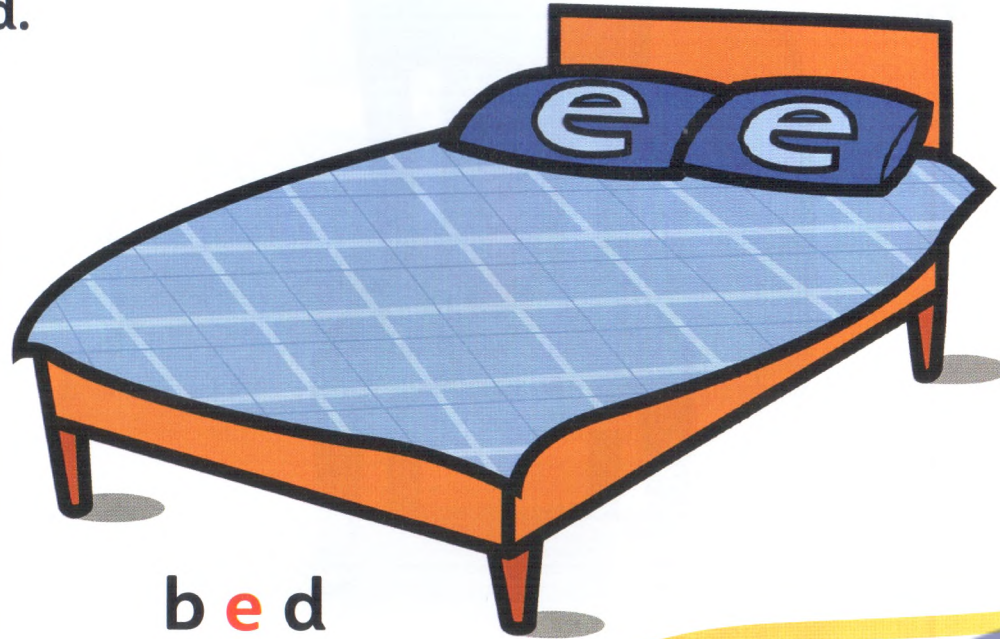
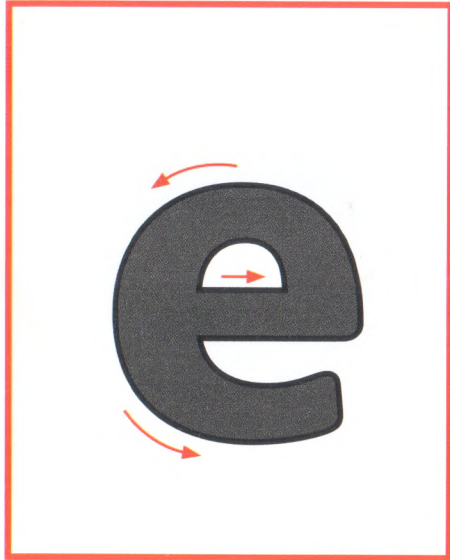

b e d

p e n



2 CD1 Listen and join in.
49

www.miladcollege.com



1 Look and find. Colour the letter.

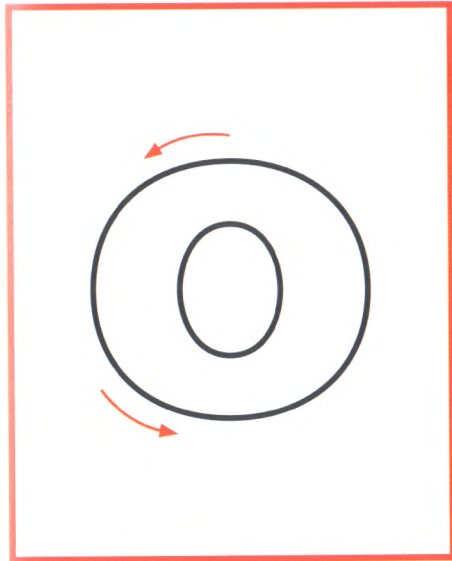

Listen and join in.

1 Look and find. Colour the letter.

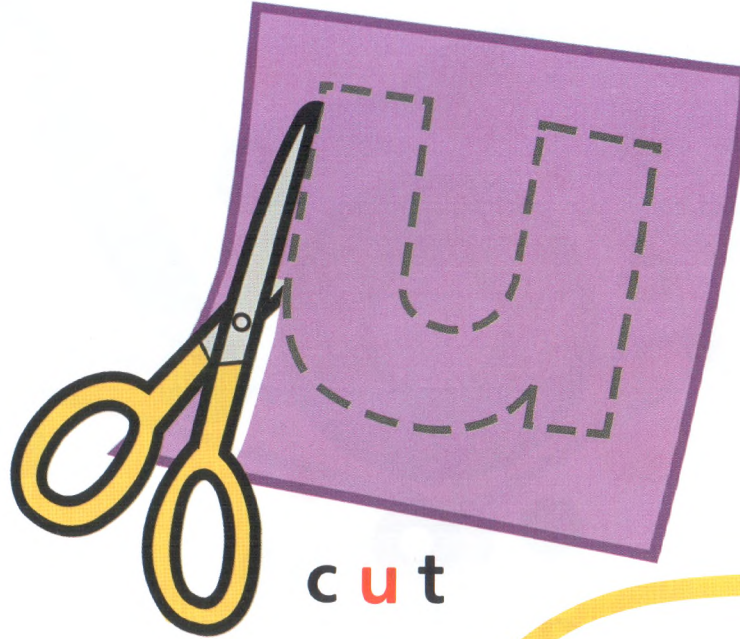
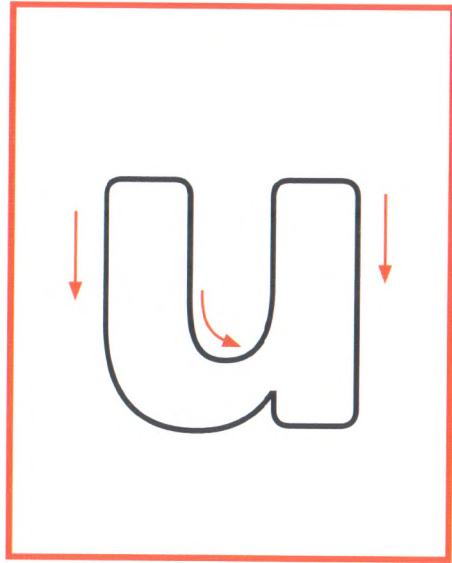

b u s



2 CD2 Listen and join in.
11

www.miladcollege.com

1 Look and find. Colour the letter.

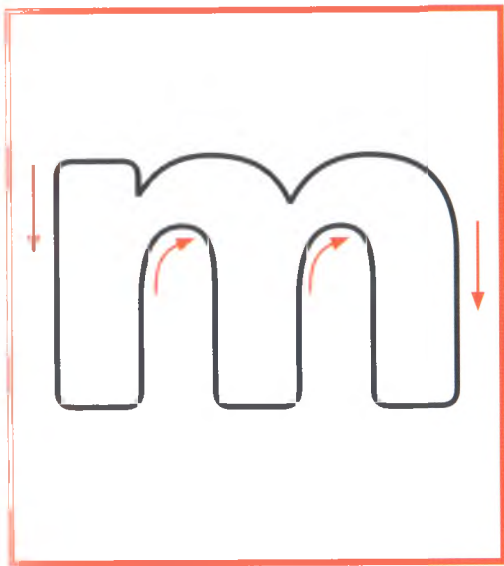

m u m

m a t



2 Listen and join in.

www.miladcollege.com

1 Look and find. Trace the letter.

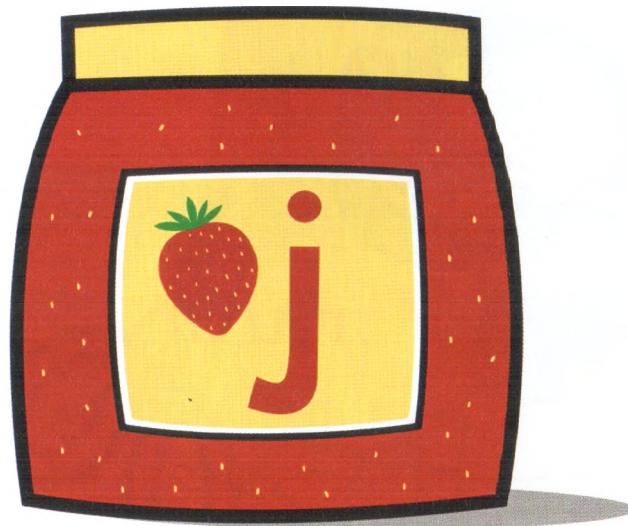
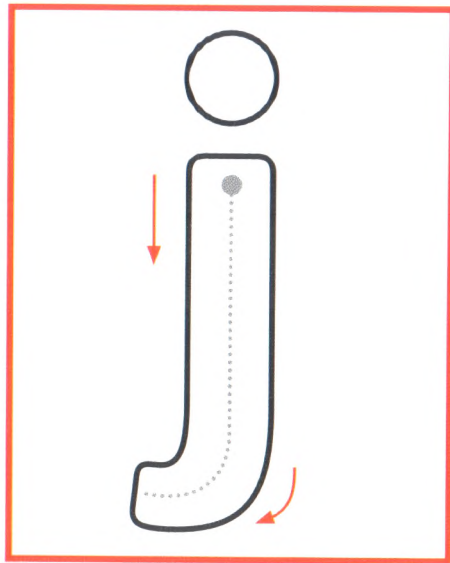

j a m



2 ^{CD2}₃₇ Listen and join in.

www.miladcollege.com

1 Look and find. Trace the letter.

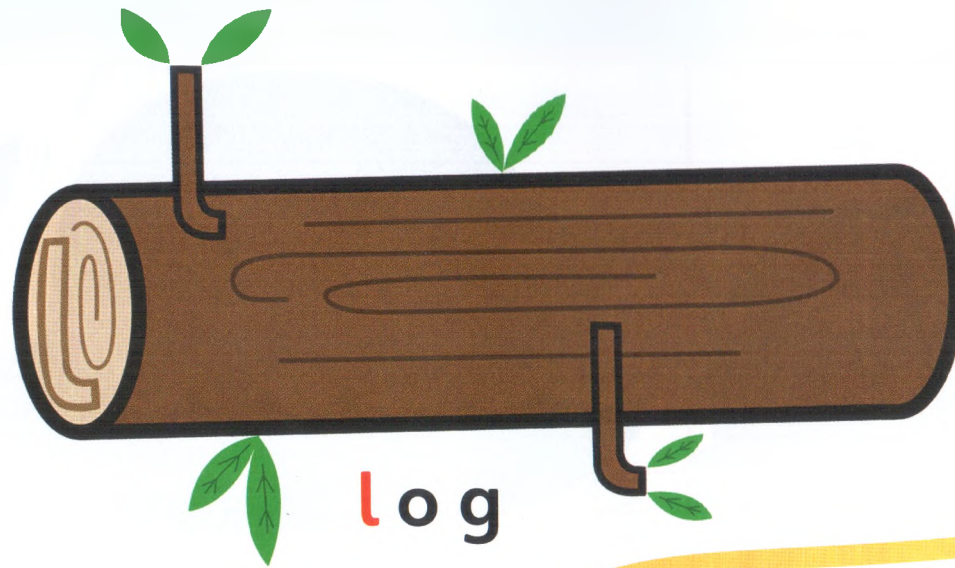
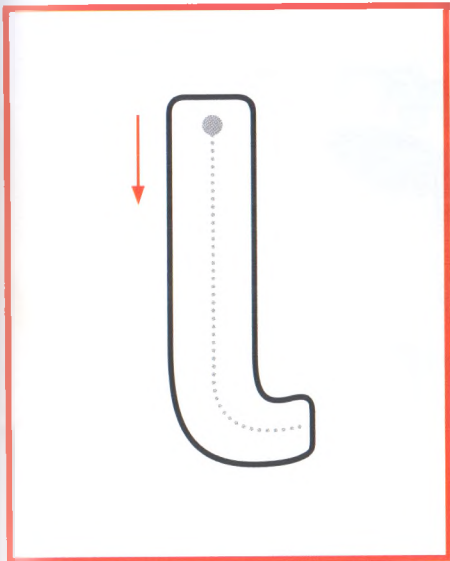

log

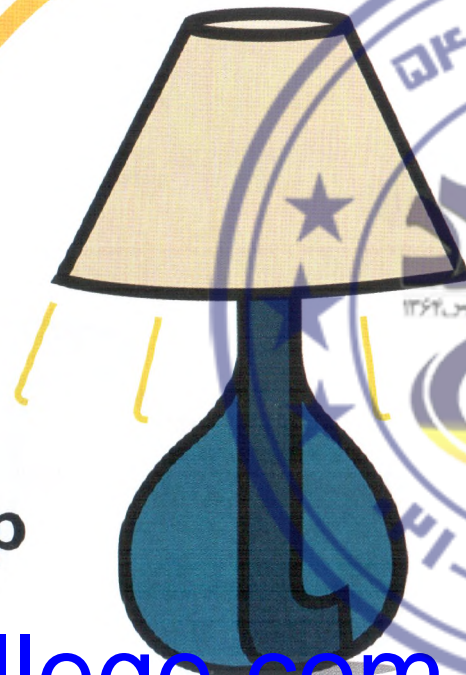

lamp

2 CD2 50 Listen and join in.



1 Look and find. Trace the letter.



w e t



w o w

2 CD2
63

Listen and join in.

www.miladcollege.com

Listen and play bingo.

j a m

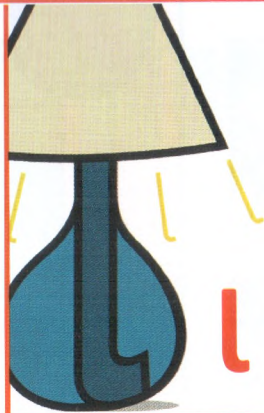

l a m p

w e t

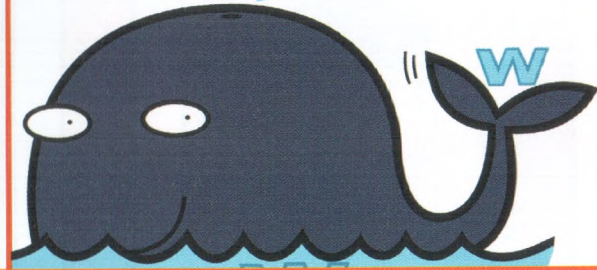

p o t

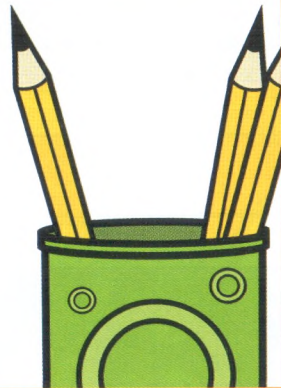

m a t

b u s



c a t

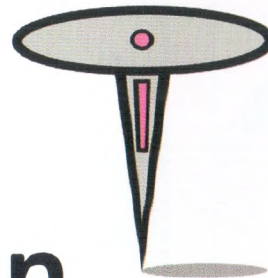
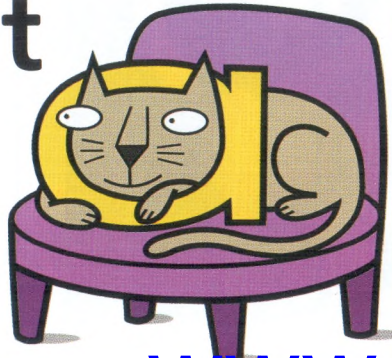

p i n

p e n



1 CD1 23

Listen to the sentences. Colour the frames.



1 CD1
50

Listen and colour the circles. Colour the frames.

Review



Listen and colour the circles. Colour the frames.

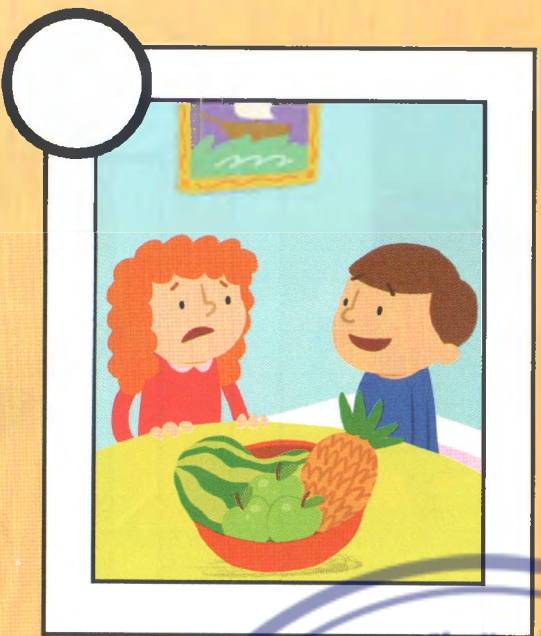
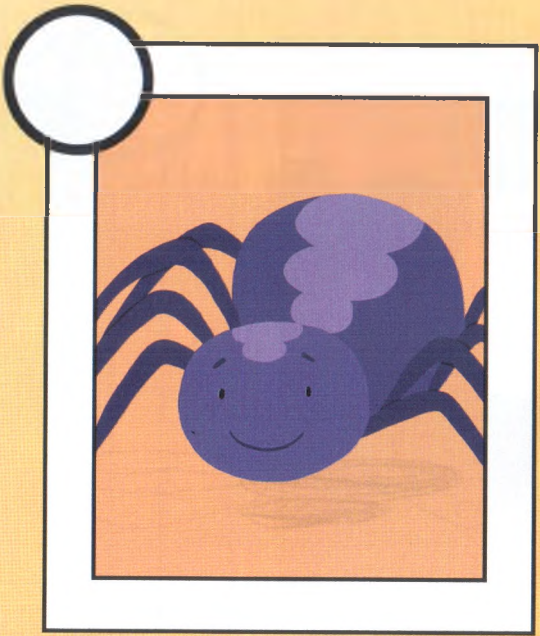

Listen and colour the circles. Colour the frames.

Review

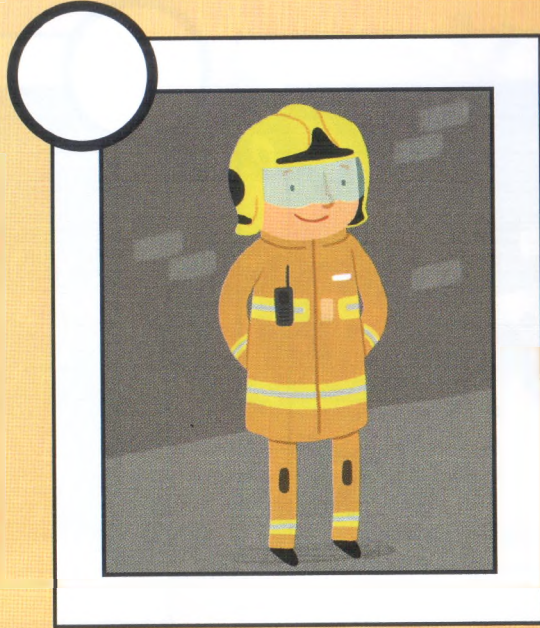

Listen and colour the circles. Colour the frames.

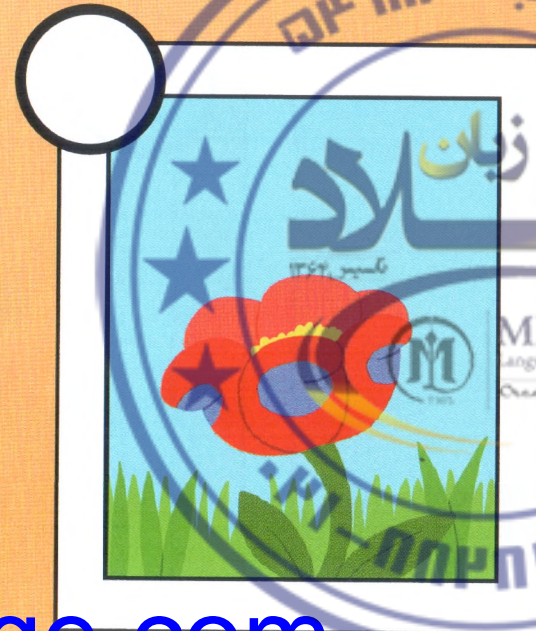



Well done!

.....
has finished Super Safari!

